



Vertical Form-Film-Seal Bagging System

The latest generation of CHRONO-BAG™ Vertical Form-Fill-Seal baggers at CHRONOS BTH are fully automatic systems, which make their own bags from rolls of polyethylene pre-printed flat film. They are intended to package a wide range of loose fill materials in bags ranging from 5 to 110 litres.

The system is suitable for both free flowing and difficult to handle bulk materials. A key feature of our VFFS product range is its compact, sturdy design that can be supplied in 2 versions VFFS-1100 Series and high-speed version VFFS-1180 Series. They can be integrated upstream to either a weighing or a volumetric feeding system, and downstream to conveying and palletising systems.

Thanks to our Form-Fill-Seal bagging technology, Chronos BTH allows you to greatly reduce your packaging material costs while offering you a great performance and unrivalled reliability.



VFFS-SERIES



CHRONO-BAG™
Bagging Systems

Vertical Form-Film-Seal Bagging System

OPTIONS AVAILABLE

Wide ranges of machine options are available to ensure the best solution for your application requirements:

- Corner sealing for compact, easily palletised bags
- Gusset forming unit
- Bag top handle former
- Hole punch unit
- Full stainless steel version
- Dust suction set up
- Movable platform systems for optimum plant utilization
- Bag marking devices
- Interchangeable forming sets and tubes, to handle any bag size
- Product press option for light and long fibrous products to ensure reliable bag sealing
- Other options available on request

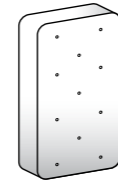

Drain hole punch

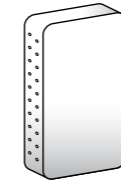

Nail hole punch side

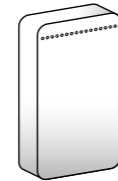

Nail hole punch top

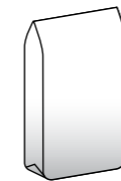

Gusseted bag



Punch handle

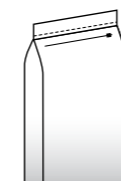

Prefabricated zipper

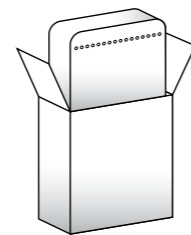

Bag in box

FEATURES AND BENEFITS

- Easy to adjust and operate
- Proven Technology providing constant production rates up to 1800 Bags/hour
- Matched high accuracy weighers and feeders for maximum outputs
- Compact, sturdy design
- Innovative low movement design to minimise spare part holding requirements
- Wide machine access allowing cleaning and maintenance to be carried out quickly and effectively
- User-friendly with a graphical touch panel interface and clear text-based operator guidance
- Designed for minimised film overlap to reduce film waste
- Solid and reliable field proven technology for highest availability
- Minimised installation costs as the system is supplied as a pre-wired/pre-tested configuration
- Ergonomic design providing good visibility and allowing easy adjustments and maintenance operations inside the guarding area
- All electrical components centralised in only one control panel

APPLICATIONS

The CHRONO-BAG™ VFFS Series is the ideal system for free flowing as well as difficult to handle bulk materials.

Horticulture

Bark, compost, mulch, peat moss, soils, etc.

Organic Products

Wood pellets, pet food, seeds, animal feed, cat litter, etc.

Minerals

Sand, gravel, concrete mix, coal, crushed stone, etc.

Chemicals

Fertiliser, plastic pellets, salt and corrosive materials, etc.

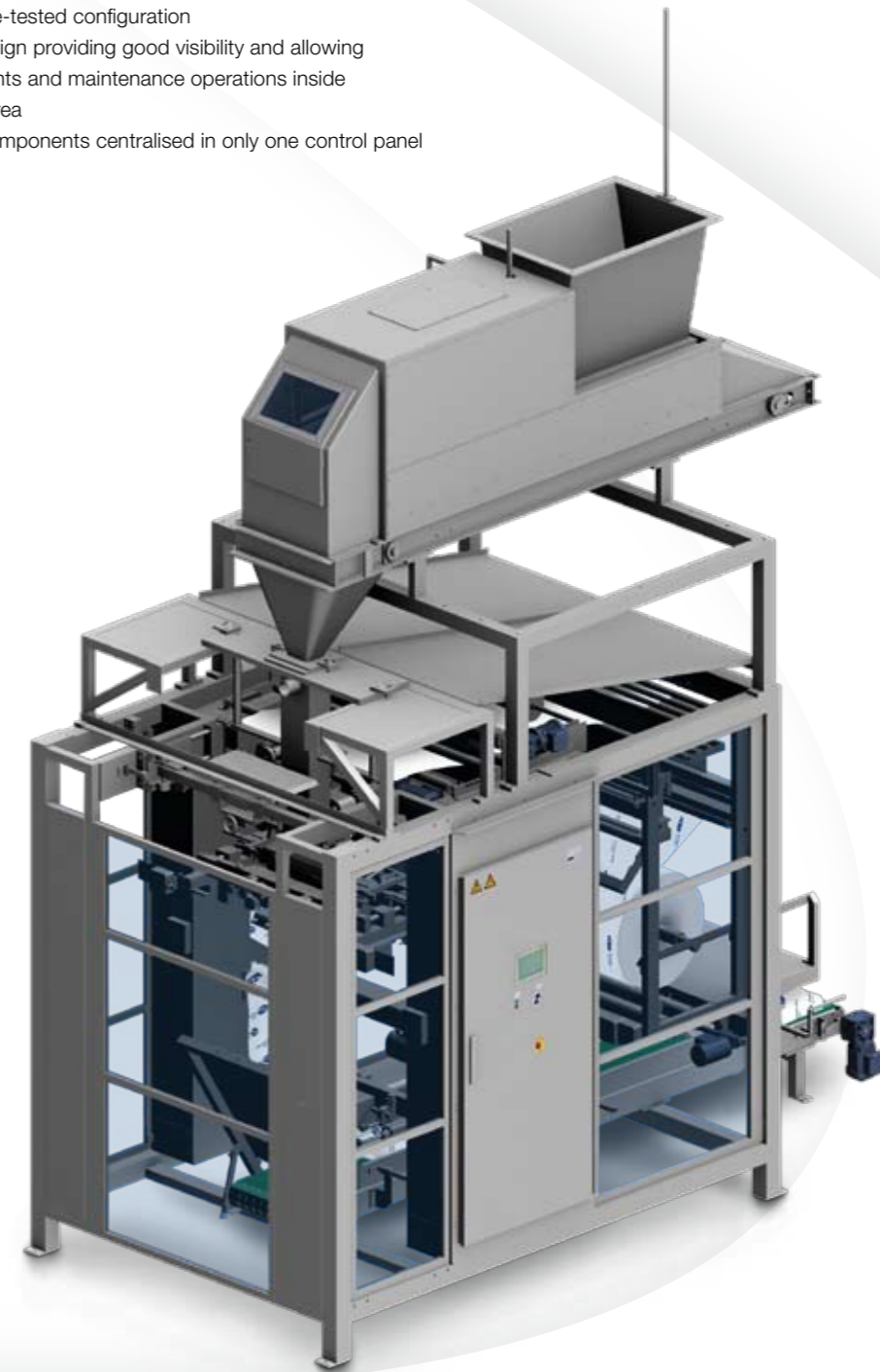

TECHNICAL DATA

VFFS-1100 Series, VFFS-1180 Series

Bag specifications

Material: Heat sealable polyethylene flat film
(registered print with I-mark or random print)
Thickness: 40 to 120 μm^*
Face Width: 190 to 580 mm
Length: 400 to 1200 mm
Gusset: 40 – 90 mm

Film roll diameter

up to 600 mm

Film width

Up to 1400 mm

Production Rate

Up to 1800 Bags/hour **

Air Consumption

100 NI/bag***

Operating pressure

6 bar

Electrical requirements

400 V / 3 Ph / 50 Hz

Operating temperature

+5° C to +40° C

* Film thickness to be verified by CHRONOS BTH team

** Depending on product characteristics, method of feeding, bag size, film thickness, etc.

*** Certain options may require higher air consumption

**** Other voltages available

TYPICAL LAYOUT

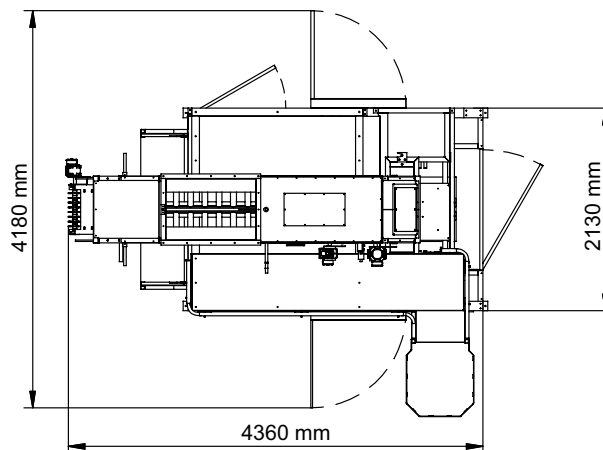
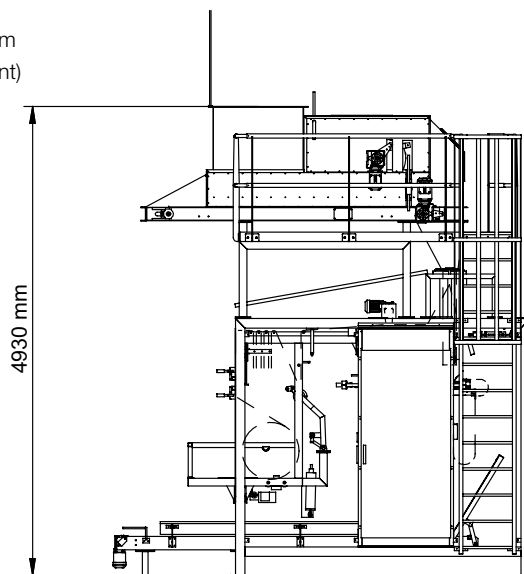

European group offices & manufacturing plants:

Chronos BTH B.V.

Eersel, The Netherlands
T: +31 (0) 497 514 988
info@chronosbth.com

Chronos BTH S.R.L.

Parma, Italy
+39 0521 29 60 11
info@chronosbth.com

Sales & service offices:

Chronos BTH GmbH

Hennef, Germany
T: +49 (0) 2242 9335 0

Chronos BTH Ltd.

Nottingham, United Kingdom
T: +44 (0) 115 935 1351

Chronos BTH S.A.

Viry-Châtillon, France
+33 (0) 1 69 12 11 50

The information contained in this brochure is based upon the latest information available at the time of publication and is designed to provide you with a general introduction to our products. We make no warranties or representations as to its accuracy. We are continually updating and improving our products and reserve the right to amend, discontinue or alter or change specifications and prices without prior notice.

© PREMIER TECH Ltd. 2010 Printed in Germany 20100415

Chronos BTH is a Premier Tech company