

AW/VW SERIES



[WWW.CHRONOSRICHARDSON.COM](http://WWW.CHRONOSRICHARDSON.COM)

HOPPER SCALES FOR RECEIVING AND  
SHIPPING BULK MATERIALS



**CHRONO-WEIGH™ AW/VW SERIES**



# WEIGHING

## HOPPER SCALES FOR RECEIVING & SHIPPING BULK MATERIALS

AW/VW

The **CHRONO-WEIGH™ AW/VW** hopper scales are recognised for their accuracy, performance and reliability. These electronically controlled weighers for receiving and shipping free-flowing bulk materials are typically used in grain silos, the feed/food industries, mills, warehouses etc. The weigher output is dependent

on the size of the weigh hopper, which can be up to 10 tons capacity. The weighers are manufactured in welded steel and are dust-tight. Infeed and weigh hopper are equipped with pneumatically operated (twin) gates. The weigh hopper has an inspection door and frame on which to place calibration weights.

### FEATURES AND BENEFITS

- Pure full loadcell systems reduces maintenance costs.
- Fulfils today's weighing system requirements for accuracy, performance and reliability.
- Removeable doors permit easy access and simple clean-down.
- Robust design for reliable constant operation.
- Modern cost-effective design and performance.
- Operation and control independent to site.
- Stainless steel contact parts - prevent corrosion when weighing aggressive materials.
- Abrasion resistant steel contact parts - reduces abrasion when weighing abrasive materials.
- Two speed material feeding - to achieve precise shipping weights.
- **CHRONO-TRONIC™ BULK 3000, 8000 or 9000** weighing & recording systems are available to suit different applications. Please ask for details.



## ● ● ● OPTIONS

- Level indicator:

Rod or probe cuts off material in-feed at the high level in the feed hopper. The level indicator in the discharge hopper only activates when the previous weighment has been conveyed away.

- Pneumatic -anti-freeze:

In operating temperatures of - 20°C to + 5°C it is recommended to install an anti-freeze system. It prevents valves, cylinders and pipes from freezing. A mixture of 1 cm<sup>3</sup> alcohol per 1 m<sup>3</sup> of air offers sufficient protection against ice formation.

- Calibration weights are positioned by pneumatic cylinders when required. This is 1/4 of the maximum weigher capacity for optimum calibration.

- Duplex infeed to achieve precise shipping weights.

## ● ● ● TECHNICAL DATA AW/VW 101-701

Weigher	Type/hopper size	Weighing range kg	Output t/h*
AW/VW	101/220	5-100	50
AW/VW	201/400	5-200	100
AW/VW	301/500	10-300	140
AW/VW	501/750	25-500	180
AW/VW	701/1000	25-500	200

## ● ● ● TECHNICAL DATA AW/VW 1002-10002

Weigher	Type/hopper size	Weighing range kg	Output t/h*
AW/VW	1002/1500	50-1,000	310
AW/VW	2002/3000	100-2,000	505
AW/VW	3002/4500	100-3,000	695
AW/VW	5002/7500	250-5,000	975
AW/VW	10002/15000	500-10,000	1,520

\* Based on grain with a bulk density of 0.75 m<sup>3</sup>

## TYPICAL LAYOUT AW/VW 1002-10002

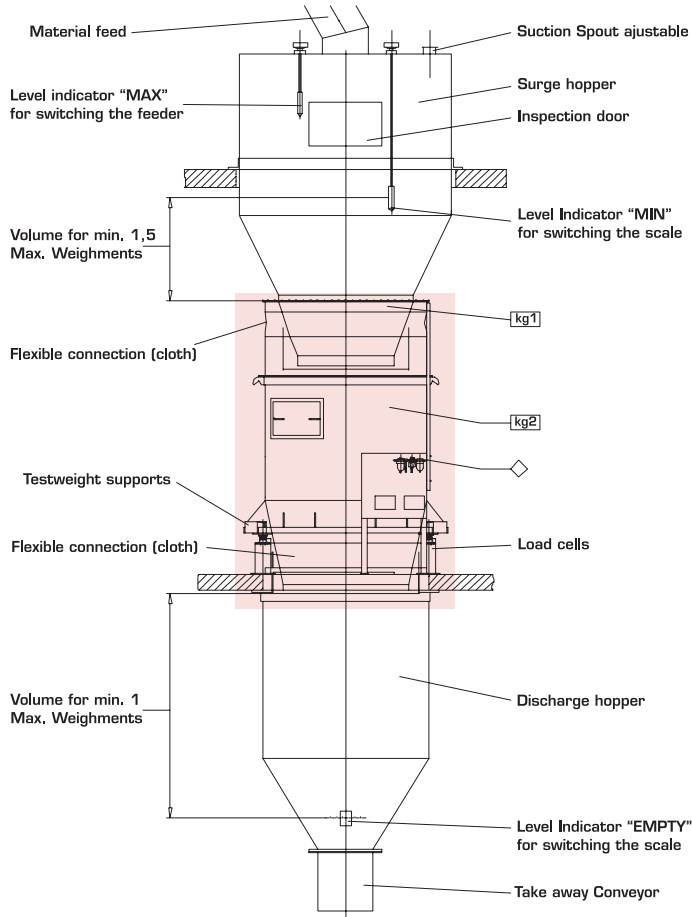

## WORLDWIDE PRESENCE

Rivière-du-Loup, CANADA • Brea, USA • Hennef, GERMANY

Viry-Châtillon, FRANCE • Nottingham, UNITED KINGDOM  
Parma, ITALY • Bangkok, THAILAND • New Delhi, INDIA

For nearly 125 years now, **Chronos Richardson Systems** has made its mark on the European and Asian markets thanks to its innovative packaging and processing solutions and approach to complete integrated system projects tailored to customers' individual needs. Armed with its experience, the inventor of the first automatic weigher is now recognized as a specialist in weighing, batching, bagging and palletising for the food, feed, chemicals, plastics, fertilizer, milling and cement industries.

**Chronos Richardson Systems** is part of the Industrial Equipment Group of Premier Tech, one of the largest players in the field of industrial flexible packaging worldwide.

**Find your solution with Chronos Richardson Systems.**



Chronos Richardson Systems GmbH, GERMANY

+49 (0) 2242 9335 0

+49 (0) 2242 9335 186

@ info@chronosrichardson.com

[www.chronosrichardson.com](http://www.chronosrichardson.com)

Chronos Richardson Ltd., UNITED KINGDOM

+44 (0) 115 935 1351

+44 (0) 115 960 6941

Chronos Richardson Srl, ITALY

+39 (0) 0521 296011

+39 (0) 0521 945857

  
A business unit of Premier Tech

The information contained in this brochure is based upon the latest information available at the time of publication and is designed to provide you with a general introduction to our products. We make no warranties or representations as to its accuracy. We are continually updating and improving our products and reserve the right to amend, discontinue or alter or change specifications and prices without prior notice.  
© Premier Tech Ltd. 2008